

METAL MAN[®]

WORK GEAR

HEAVY DUTY SINGLE/DUAL BOTTLE WELDING CART

OWNER'S MANUAL



5/2015



WARNING:

Read carefully and understand all **ASSEMBLY AND OPERATION INSTRUCTIONS** before operating. Failure to follow the safety rules and other basic safety precautions may result in serious personal injury.

WARRANTY

METAL MAN WORK GEAR CO

EFFECTIVE JANUARY 1, 2013

LIMITED WARRANTY

This warranty applies to the original purchaser and is subject to the terms and conditions listed below. This Limited Warranty is for new equipment sold after the above date, providing coverage for defects in material and workmanship at the time it is shipped from the factory.

Limited to the warranty periods below, Metal Man Work Gear Co will repair or replace the item under warranty that fails due to defects in material and workmanship. Metal Man Work Gear must be notified within 30 days of the failure, so as to provide instructions on how to proceed with the repair of your welder and warranty claim processing. Warranty period begins at the time the welder is purchased from and Authorized Reseller of Metal Man Work Gear Co. products. **Keep your receipt as proof of purchase.**

Warranty Periods

Limited Warranty is divided into three categories. No Warranty, 90 days, 1 year and 3 year.

No Warranty

Normal wear items, MIG gun parts (contact tips, nozzle, contact tip adapter, MIG gun liner), drive roll, electrode holder, ground clamps, Plasma torch parts (nozzle, electrode, diffuser, cover) are considered consumable items and are not covered under warranty.

90 days

Parts for Metal Man Work Gear welding carts and welding cabinets. This warranty covers the absence of or defective parts.

1 year

Parts and Labor on MIG gun parts (except those listed under normal wear items), cables, regulator, and plasma torch (except those listed under normal wear items). Any shipping related to warranty repair is the responsibility of the customer.

1 year/3 year

Please see your product information to determine if your product has a 1 year or 3 year warranty. This warranty covers parts and Labor on items such as: transformer, reactor, rectifier, solenoid valve, PC Board, switches, controls, gas valve, drive motor, drive system other than drive roll and any other component that requires the removal of the sheet metal to access. Any shipping related to warranty repair is the responsibility of the customer.

Voiding Warranty

Warranty does not apply to: Shipping Damage, Misuse and abuse of the unit, alteration of the unit in any way.

Warranty Claim

This is a parts and labor warranty. **Do not return your unit to the retailer you purchased it from.** Retain your receipt in the case a warranty claim is needed. No warranty will be provided without the original receipt from an authorized reseller of Metal Man Work Gear Products. To make a warranty claim, call our welder help line at 888-762-4045, M-F 8:00 am to 5:00 PM Central time or email sales@metalmangear.com.

GENERAL SAFETY RULES



WARNING: Read and understand all instructions. Failure to follow all instructions listed below may result in serious injury.



CAUTION: Do not allow persons to operate or assemble this Flux Core 125 until they have read this manual and have developed a thorough understanding of how the Flux Core 125 works.



WARNING: The warnings, cautions, and instructions discussed in this instruction manual cannot cover all possible conditions or situations that could occur. It must be understood by the operator that common sense and caution are factors which cannot be built into this product, but must be supplied by the operator.

SAVE THESE INSTRUCTIONS

IMPORTANT SAFETY CONSIDERATIONS

1.1 Your Welding Environment

- Keep the environment you will be welding in free from flammable materials.
- Always keep a fire extinguisher accessible to your welding environment.
- Always have a qualified person install and operate this equipment.
- Make sure the area is clean, dry and ventilated. Do not operate the welder in humid, wet or poorly ventilated areas.
- Always have your welder maintained by a qualified technician in accordance with local, state and national codes.
- Always be aware of your work environment. Be sure to keep other people, especially children, away from you while welding.
- Keep harmful arc rays shielded from the view of others.
- Mount the welder on a secure bench or cart that will keep the welder secure and prevent it from tipping over or falling.

1.2 Your Welder's Condition

- Check ground cable, power cord and welding cable to be sure the insulation is not damaged. Always replace or repair damaged components before using the welder.
- Check all components to ensure they are clean and in good operating condition before use.

1.3 Use of Your Welder

CAUTION

Do not operate the welder if the output cable, electrode, torch, wire or wire feed system is wet. Do not immerse them in water. These components and the welder must be completely dry before attempting to use them.

- Follow the instructions in this manual.
- Keep welder in the off position when not in use.
- Connect ground lead as close to the area being welded as possible to ensure a good ground.
- Do not allow any body part to come in contact with the welding wire if you are in contact with the material being welded, ground or electrode from another welder.
- Do not weld if you are in an awkward position. Always have a secure stance while welding to prevent accidents. Wear a safety harness if working above ground.
- Do not drape cables over or around your body.
- Wear a full coverage helmet with appropriate shade (see ANSI Z87.1 safety standard) and safety glasses while welding.
- Wear proper gloves and protective clothing to prevent your skin from being exposed to hot metals, UV and IR rays.
- Do not overuse or overheat your welder. Allow proper cooling time between duty cycles.
- Keep hands and fingers away from moving parts and stay away from the drive rolls.
- Do not point MIG gun at any body part of yourself or anyone else.
- Always use this welder in the rated duty cycle to prevent excessive heat and failure.

1.4 Specific Areas of Danger, Caution or Warning



Electrical Shock

▲ WARNING

Electric arc welders can produce a shock that can cause injury or death. Touching electrically live parts can cause fatal shocks and severe burns. While welding, all metal components connected to the wire are electrically hot. Poor ground connections are a hazard, so secure the ground lead before welding.

- Wear dry protective apparel: coat, shirt, gloves and insulated footwear.
- Insulate yourself from the work piece. Avoid contacting the work piece or ground.
- Do not attempt to repair or maintain the welder while the power is on.
- Inspect all cables and cords for any exposed wire and replace immediately if found.
- Use only recommended replacement cables and cords.
- Always attach ground clamp to the work piece or work table as close to the weld area as possible.
- Do not touch the welding wire and the ground or grounded work piece at the same time.
- Do not use a welder to thaw frozen pipes.



Fumes and Gases

▲ WARNING

- Fumes emitted from the welding process displace clean air and can result in injury or death.
- Do not breathe in fumes emitted by the welding process. Make sure your breathing air is clean and safe.
- Work only in a well-ventilated area or use a ventilation device to remove welding fumes from the environment where you will be working.
- Do not weld on coated materials (galvanized, cadmium plated or containing zinc, mercury or barium). They will emit harmful fumes that are dangerous to breathe. If necessary use a ventilator, respirator with air supply or remove the coating from the material in the weld area.
- The fumes emitted from some metals when heated are extremely toxic. Refer to the material safety data sheet for the manufacturer's instructions.
- Do not weld near materials that will emit toxic fumes when heated. Vapors from cleaners, sprays and degreasers can be highly toxic when heated.



UV and IR Arc Rays

⚠ DANGER

The welding arc produces ultraviolet (UV) and infrared (IR) rays that can cause injury to your eyes and skin. Do not look at the welding arc without proper eye protection.

- Always use a helmet that covers your full face from the neck to top of head and to the back of each ear.
- Use a lens that meets ANSI standards and safety glasses. For welders under 160 Amps output, use a shade 10 lens; for above 160 Amps, use a shade 12. Refer to the ANSI standard Z87.1 for more information.
- Cover all bare skin areas exposed to the arc with protective clothing and shoes. Flame-retardant cloth or leather shirts, coats, pants or coveralls are available for protection.
- Use screens or other barriers to protect other people from the arc rays emitted from your welding.
- Warn people in your welding area when you are going to strike an arc so they can protect themselves.



Fire Hazards

⚠ WARNING

Do not weld on containers or pipes that contain or have had flammable, gaseous or liquid combustibles in them. Welding creates sparks and heat that can ignite flammable and explosive materials.

- Do not operate any electric arc welder in areas where flammable or explosive materials are present.
- Remove all flammable materials within 35 feet of the welding arc. If removal is not possible, tightly cover them with fireproof covers.
- Take precautions to ensure that flying sparks do not cause fires or explosions in hidden areas, cracks or areas you cannot see.
- Keep a fire extinguisher close in the case of fire.
- Wear garments that are oil-free with no pockets or cuffs that will collect sparks.
- Do not have on your person any items that are combustible, such as lighters or matches.
- Keep work lead connected as close to the weld area as possible to prevent any unknown, unintended paths of electrical current from causing electrical shock and fire hazards.
- To prevent any unintended arcs, cut wire back to ¼" stick out after welding.



Hot Materials

⚠ CAUTION

Welded materials are hot and can cause severe burns if handled improperly.

- Do not touch welded materials with bare hands.
- Do not touch MIG gun nozzle after welding until it has had time to cool down.

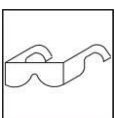

Sparks/Flying Debris

⚠ CAUTION

Welding creates hot sparks that can cause injury. Chipping slag off welds creates flying debris.

- Wear protective apparel at all times: ANSI-approved safety glasses or shield, welder's hat and ear plugs to keep sparks out of ears and hair.



Electromagnetic Field

⚠ CAUTION

-Electromagnetic fields can interfere with various electrical and electronic devices such as pacemakers.

- Consult your doctor before using any electric arc welder or cutting device
- Keep people with pacemakers away from your welding area when welding.
- Do not wrap cable around your body while welding.
- Wrap MIG gun and ground cable together whenever possible.
- Keep MIG gun and ground cables on the same side of your body.



Shielding Gas Cylinders Can Explode

⚠ WARNING

High pressure cylinders can explode if damaged, so treat them carefully.

- Never expose cylinders to high heat, sparks, open flames, mechanical shocks or arcs.
- Do not touch cylinder with MIG gun.
- Do not weld on the cylinder
- Always secure cylinder upright to a cart or stationary object.
- Keep cylinders away from welding or electrical circuits.
- Use the proper regulators, gas hose and fittings for the specific application.
- Do not look into the valve when opening it.
- Use protective cylinder cap whenever possible

1.5 Proper Care, Maintenance and Repair

⚠ DANGER

- Always have power disconnected when working on internal components.
- Do not touch or handle PC board without being properly grounded with a wrist strap. Put PC board in static proof bag to move or ship.
- Do not put hands or fingers near moving parts such as drive rolls of fan

USE AND CARE

- **Do not modify this unit in any way.** Unauthorized modification may impair the function and/or safety and could affect the life of the equipment. There are specific applications for which this unit was designed.
- **Always check of damaged or worn out parts before using this unit.** Broken parts will affect the operation. Replace or repair damaged or worn parts immediately.
- **Store idle.** When this unit is not in use, store it in a secure place out of the reach of children. Inspect it for good working condition prior to storage and before re-use.

SPECIFICATIONS

Item	Description
Overall Dimensions	47-1/2 in. x 21 in. x 39-3/4 in.
Top Shelf Usable Space	15-1/4 in. x 22-1/2 in.
Bottom Shelf Usable Space	15-1/2 in. x 21-7/8 in. x 18 in. Clearance
Product Weight	53-1/2 lbs.
Load Capacity	400 lbs.

DESCRIPTION

The METAL MAN Heavy Duty Single/Dual Bottle Welding Cart is designed for multiple uses as a welding cart. First it can be used to hold portable wire welders, plasma cutters and TIG welders along with the bottle of shielding gas needed for that application. Its unique Cylinder rack allows you to configure it to carry one bottle of gas up to 10 inches in diameter and up to 300 cu. Ft.; or two separate bottles of gas up to 7-1/2 inches in diameter or 150 cu. Ft each.

The second use for this welding cart could be to hold two separate welders or a welder and a plasma cutter. The bottom shelf has an 18 inch clearance, giving able space to store one unit on the top shelf and one unit on the bottom shelf. Two units, may require two bottles of shielding gas. Simply configure the cylinder rack to the dual bottle cylinder configuration.

A third use for the Heavy Duty Single/Dual Bottle Welding Cart is as a power source and feeder cart. The bottom shelf has an 18 inch clearance, giving able space to store a smaller, inverter-based welding power source on the bottom shelf. The top shelf has ample space to fit a wire feeder. In addition, the top of the cylinder securement rack can be removed to accommodate the wire feeder spool holder and a large spool of wire.

This cart's top shelf is approximately 25 inches from the floor, putting the machine controls at a comfortable operating height. A 20 inch wide base, 8 inch rear wheels, locking front casters, and fold down handle make this cart stable and easy to maneuver. This unit also has two sets of cable wraps to organize all the welding cables safely.

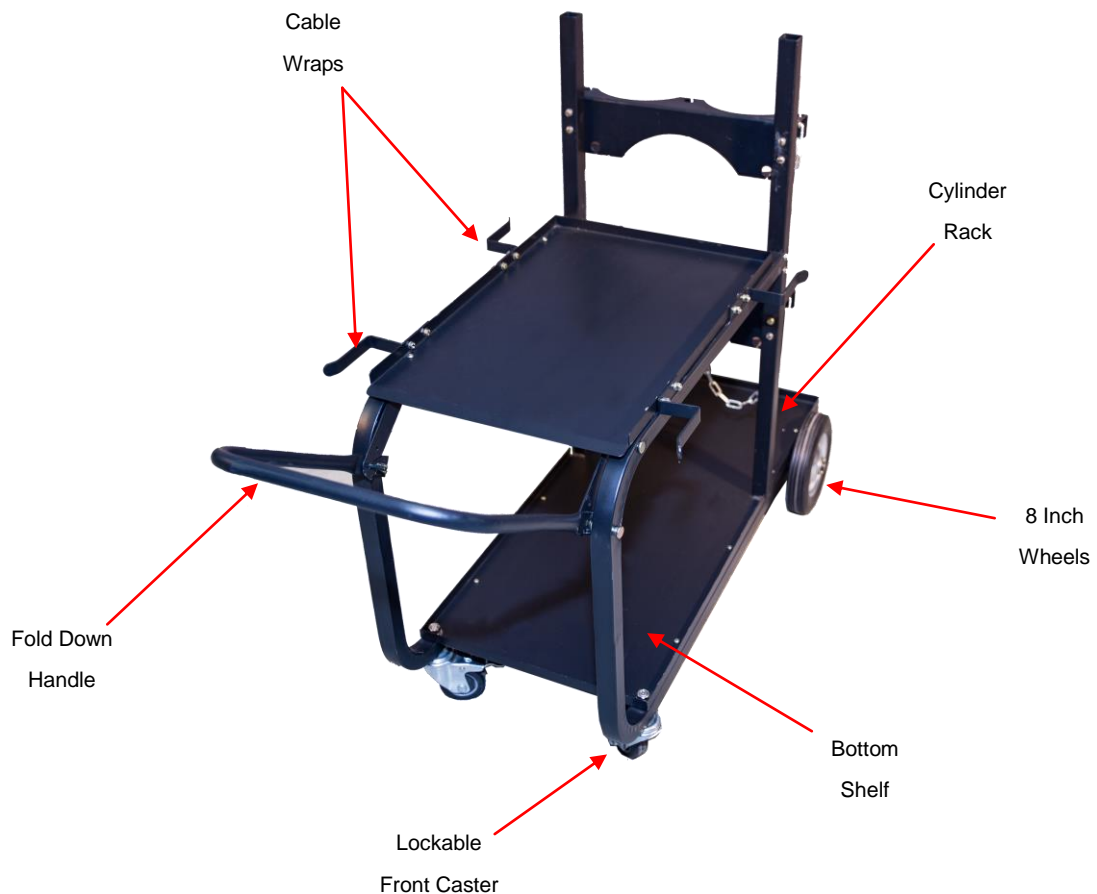

TYPICAL APPLICATIONS

1.1 Portable Welder Cart



1.2 Portable Welder Plus Plasma Cutter Cart (Dual Welder)



1.3 Inverter Power Source & Feeder Cart

Portable with Single or Dual Cylinders



Portable with Cylinder Rack Removed



1.4 Single Cylinder Securement



Dual Cylinder Securement



ASSEMBLY

1. On a flat surface, stand the two frame pieces up on their long side.
2. Lay the bottom shelf lip up on top of the two frame pieces.
3. Line up the pre-drilled holes in the bottom shelf with the pre-drilled holes in the long side of one of the frame pieces.
4. From the bottom of one frame piece, insert the threaded shaft of one caster, through the pre-drilled hole of the frame, then up through the pre-drilled hole of the bottom shelf.
5. Secure caster with a flat washer, lock washer and nut.
6. Repeat steps 3 through 5 using the other frame piece.
7. Use 8 of the self-tapping screws to secure the bottom shelf to the frame using the pre-drilled holes in the bottom shelf and frame.
8. Slide the axle through the pre-drilled axle clip on the bottom of the frame.
9. Slide a wheel on each side.
10. Secure each wheel with a flat washer and cotter pin.
11. Find the top shelf.
12. Align the pre-drilled holes in the top shelf with the pre-drilled holes in the frame pieces. Use 4 self-tapping screws to secure the top shelf to the frame.
13. Located the pre-drilled hole on the front left frame just under the top shelf. From the outside of the frame, insert one of the clevis pins through the pre-drilled hole in the frame. Slide a latch and then a flat washer onto the open end of the clevis pin. Secure both with a cotter pin.
14. Repeat the last step for the right side frame.
15. Locate the other pre-drilled hole on the front left frame. From the outside of the frame, insert one of the clevis pins through the pre-drilled hole in the frame. Slide the pre-drilled hole in one end of the handle onto the clevis pin. Add a flat washer and secure with a cotter pin.
16. Repeat the last step for the right side frame.
17. Find one of the cable holders. Make note of the two pre-drilled mounting holes in the left front lip of the top shelf. Position the cable holder so the pre-drilled mounting holes in the cable holder align with the pre-drilled mounting holes in the lip of the top shelf. Position this cable holder so the opening goes to the front of the cart. Using a hex bolt, slide on a flat washer and slide the bolt through the pre-drilled holes in the cable holder and into the matching pre-drilled holes in the top shelf. Secure with a flat washer, lock washer and Hex Nut. Repeat for the other mounting hole.
18. Still on the left side of the cart, find the two pre-drilled mounting holes on the left back lip of the top shelf. Position the cable holder so the pre-drilled mounting holes in the cable holder align with the pre-drilled mounting holes in the lip of the top shelf. Position this cable holder so the opening goes to the back of the cart. Using a hex bolt, slide on a flat washer and slide the bolt through the pre-drilled holes in the cable holder and into the matching pre-drilled holes in the top shelf. Secure with a flat washer, lock washer and Hex Nut. Repeat for the other mounting hole.
19. Repeat the last two steps for the right side of the cart.
20. Find one of the Cylinder Support Vertical Tubes. On the back left side of the cart frame, slide the small end of the Cylinder Support Vertical Tube into the square opening in the cart frame. Make certain the pre-drilled mounting holes in the Cylinder Support Vertical Tube match up with the pre-drilled mounting holes in the square opening of the cart frame. Using a long hex bolt, slide on a flat washer and slide the bolt through the pre-drilled holes in the

- cart frame and into the matching pre-drilled holes in the Cylinder Support Vertical Tubes. Secure with a flat washer, lock washer and Hex Nut. Repeat for the other mounting hole. Then repeat for the other side of the frame.
21. Locate one of the Cylinder Support Brackets. After reviewing the Cylinder Support Bracket, you will see that it can be positioned and set up for a single cylinder or two cylinders. Choose the cylinder orientation you want and align the pre-drilled mounting holes with the pre-drilled mounting holes in the Cylinder Support Vertical Tubes. Using a long hex bolt, slide on a flat washer and slide the bolt through the pre-drilled holes in the Cylinder Support Vertical Tubes and into the matching pre-drilled holes in the Cylinder Support Bracket. Secure with a flat washer, lock washer and Hex Nut. Repeat for the other mounting hole. Then repeat for the other side of the Cylinder Support Vertical Tubes.
 22. Using the last Cylinder Support Bracket, find the matching mounting holes on the back of the two frame pieces. Using a long hex bolt, slide on a flat washer and slide the bolt through the pre-drilled holes in the cart frame and into the matching pre-drilled holes in the Cylinder Support Bracket. Secure with a flat washer, lock washer and Hex Nut. Repeat for the other mounting hole. Then repeat for the other side of the frame.
 23. Put the Gas Cylinder Retaining Chain in the open slots in the Cylinder Support Bracket.

DIAGRAM & PARTS LIST

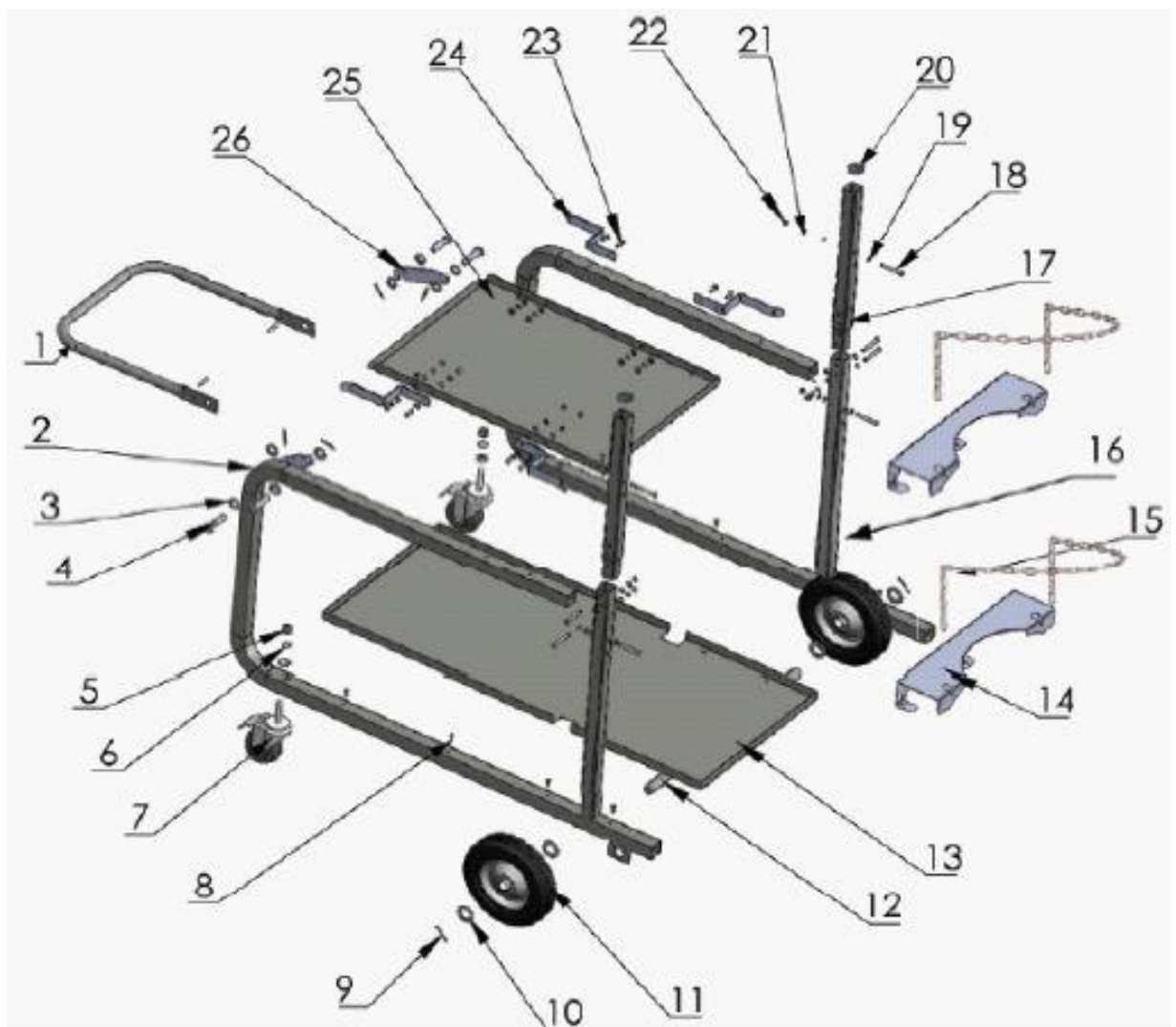

Reference #	Description	Part Number	Qty.
1	HANDLE	105100136	1
2	RIGHT SIDE FRAME	105100137	1
3	CLEVIS PIN	105100138	4
4	HEX NUT M12	105100139	4
5	LOCK WASHER M12	105100140	2
6	FLAT WASHER M12	105100002	8
7	CASTER	105100141	2
8	SELF TAPING SCREW	105100013	13
9	COTTER PIN	105100001	6
10	FLAT WASHER 20	105100074	8
11	WHEEL	105100073	2
12	AXLE	105100142	1
13	BOTTOM SHELF	105100143	1
14	GAS CYLINDER SUPPORT BRACKET	105100144	2
15	GAS CYLINDER RETAINING CHAIN	105100007	2
16	LEFT SIDE FRAME	105100145	1
17	CYLINDER SUPPORT VERTICLE TUBE	105100146	2
18	HEX BOLT M6*45	105100147	12
19	FLAT WASHER 6	105100009	31
20	TUBE PLUG	105100148	2
21	LOCK WASHER 6	105100011	21
22	HEX NUT M6	105100012	21
23	HEX BOLT M6*16	105100008	8
24	CABLE HOLDER	105100149	4
25	TOP SHELF	105100150	1
26	LATCH	105100018	2

For replacement parts or technical questions, please contact our welder help line at **1-888-762-4045**.



Distributed by
 METAL MAN WORK GEAR COMPANY
 1760 PROSPECT CT #120
 APPLETON WI 54914
www.metalmangear.com
 Made in China