

e684x1

optrel®  
swiss made 





QUICK START GUIDE .....	4
FUNCTIONS.....	6
SPARE PARTS .....	8
ENGLISH.....	11
DEUTSCH .....	12
FRANÇAIS.....	13
SVENSKA.....	14
ITALIANO .....	15
ESPAÑOL.....	16
PORTUGUÊS.....	17
NEDERLANDS .....	18
SUOMI.....	19
DANSK .....	20
NORSK.....	21
POLSKI.....	22
ČEŠTINA .....	23
中文.....	24
MAGYAR .....	25
TÜRKÇE.....	26
日本語.....	27
ΕΛΛΗΝΙΚΑ.....	28
БЪЛГАРСКИ.....	29
SLOVENSKY .....	30
SLOVENSKI .....	31
ROMÂNĂ.....	32
EESTI .....	33
LIETUVIŠKAI.....	34
LATVIEŠU.....	35
РУССКИЙ.....	36
HRVATSKI.....	37
GAEILGE.....	38
MALTI .....	39

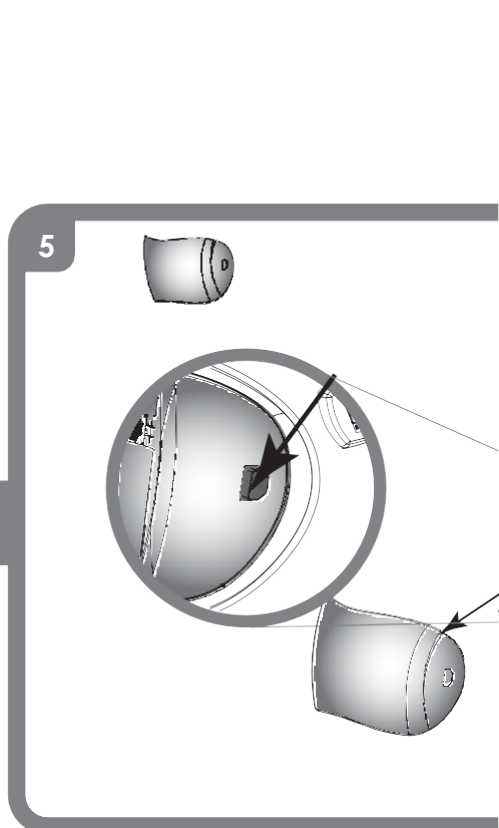
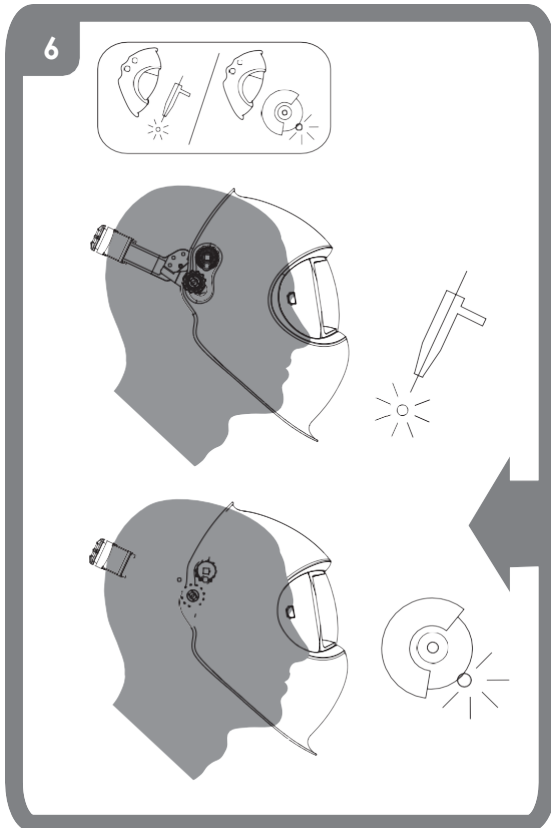
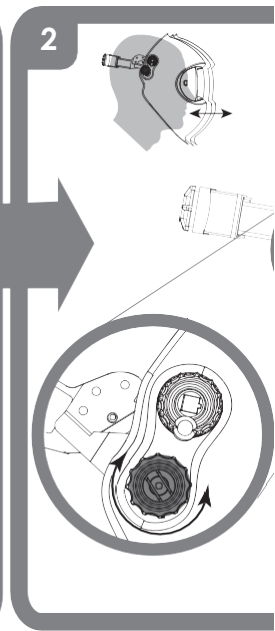
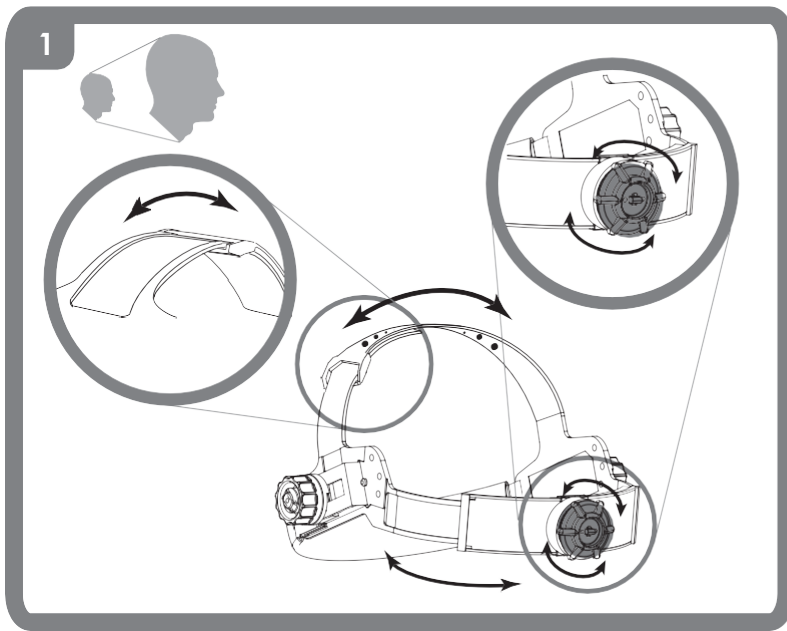

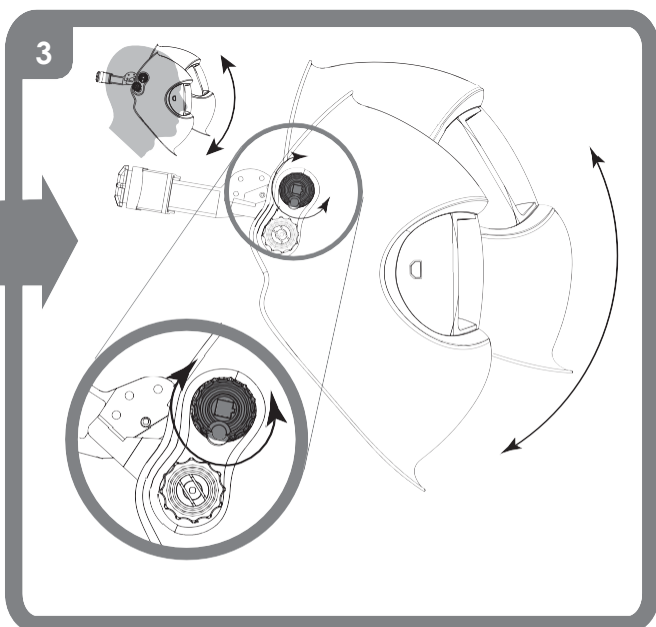
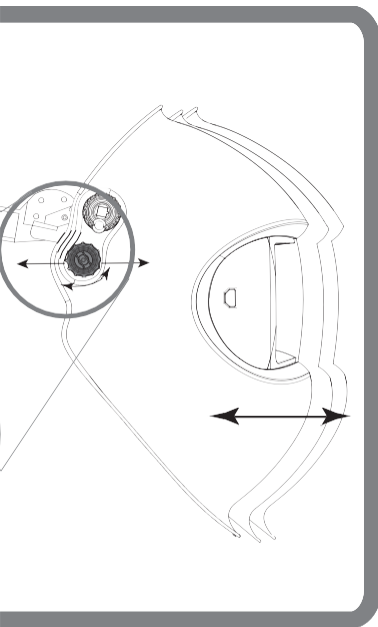

# Quick Start Guide

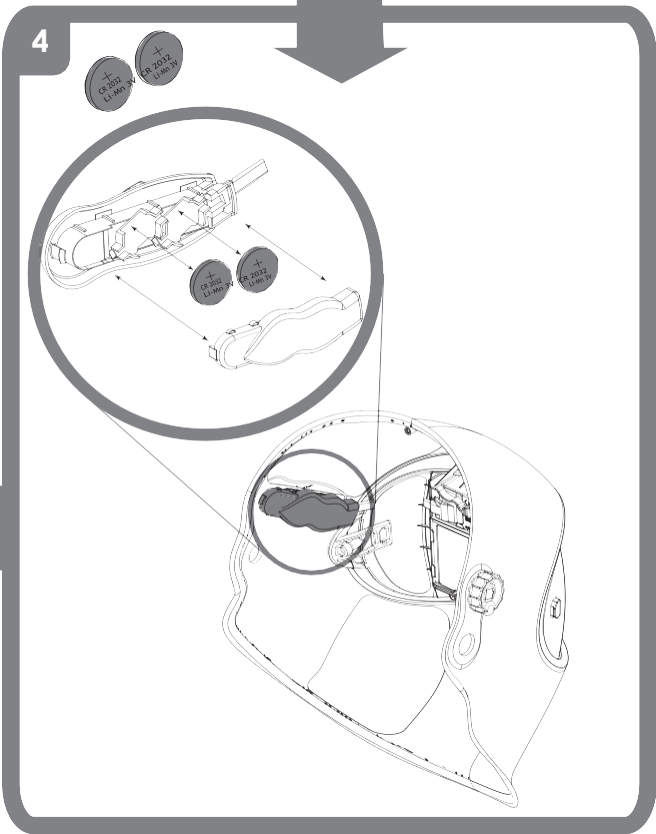

## AUTO MODE



Choose Auto Mode

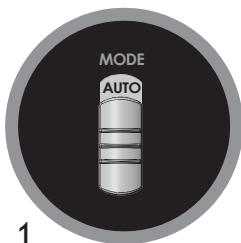

+/- 2 Shade No.



# functions

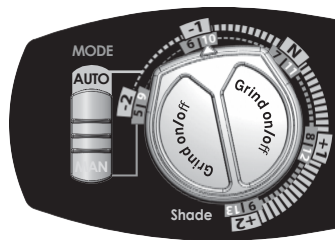

## MANUAL MODE



Choose Manual Mode

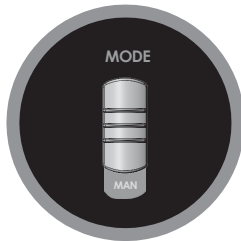

Manual Range 5-9/9-13

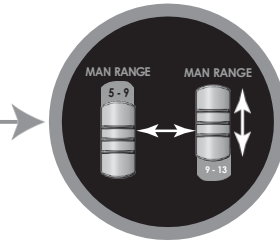

## GRIND MODE



GRIND ON / OFF

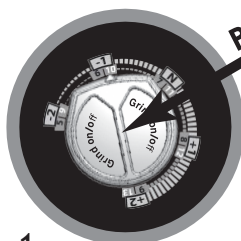

2.

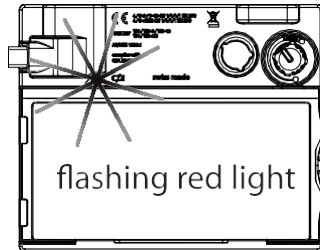



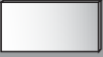

inside cover lens

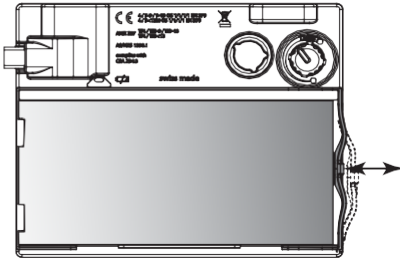

1.

SP05

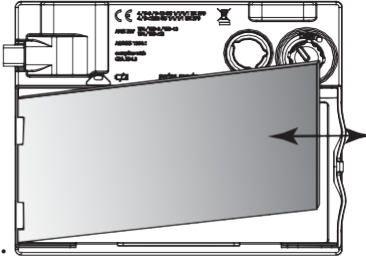

2.



front cover lens

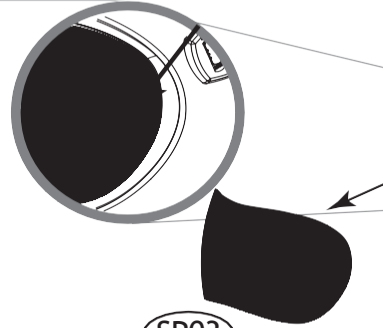

SP03

# spare parts



cartridge

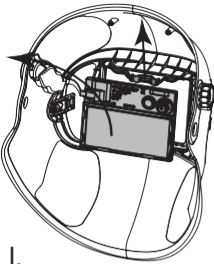

I.

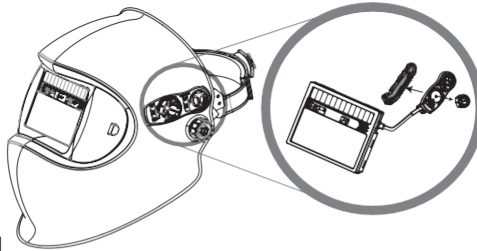

II.

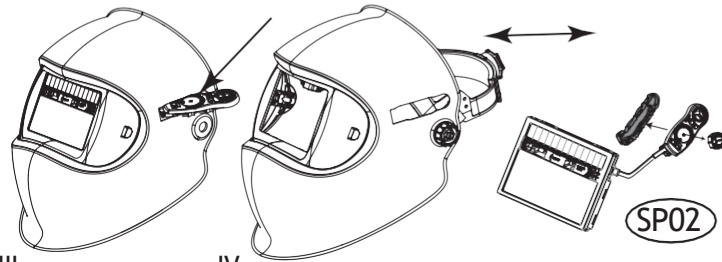

III.

IV.

SP02



adjust headband

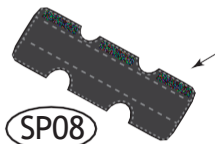

SP08

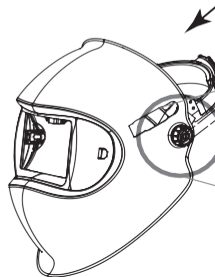

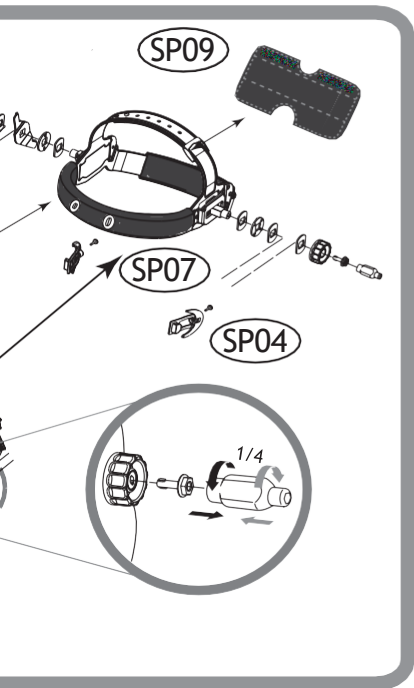
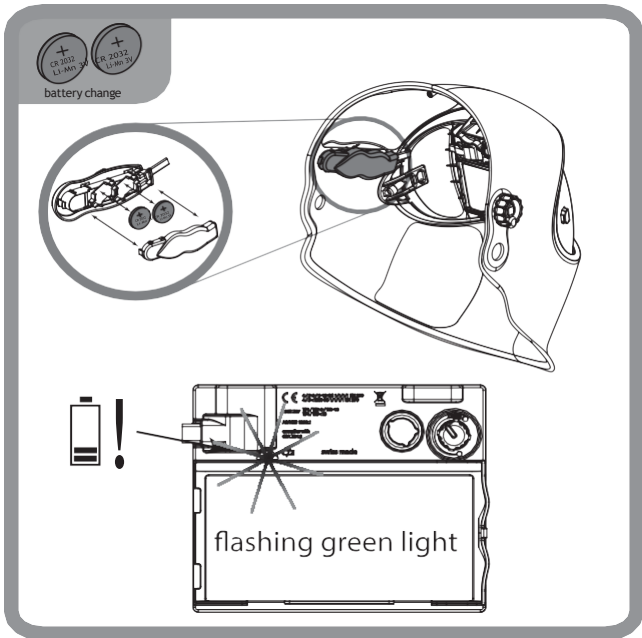
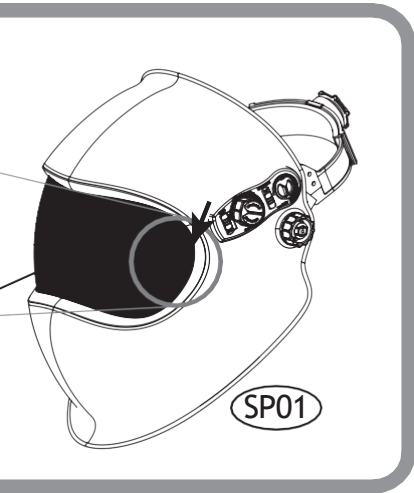







spare parts		order numbers see page 42
		SP01
		SP02
		SP03
		SP04
		SP05
		SP06
		SP07
		SP08
		SP09

# Schutzstufentabelle EN169

## Shade level chart EN169

# Tableau des niveaux de protection EN169

## Tabella dei livelli di protezione EN169

Process	Ampere																						
	1.5	6	10	15	30	40	60	70	100	125	150	175	200	225	250	300	350	400	450	500	600		
MMA 	8						9	10	11	12			13			14							
MIG heavy metals 							9		10		11		12		13		14						
MIG light metals, Al, Stainless 									10		11		12		13		14						
TIG 							8		9		10		11		12		13						
MAG 	8						9	10	11			12			13								
Plasma cutting 									9	10	11	12		13									
Micro plasma welding 	4	5	6	7	8	9	10	11	12														

Je nach persönlichem Empfinden kann die nächst höhere oder tiefere Schutzstufe verwendet werden.

According to the perception of the welder it is possible to use the next higher or lower shade number.

Selon la perception du soudeur il est possible d'utiliser un échelon de protection plus haut ou plus bas.

A seconda della sensibilità personale è possibile impostare il livello di protezione immediatamente superiore o inferiore.

Die auf dem Schweißerschutzfilter angebrachte Kennzeichnung bedeutet:

4/ 5-13 OS / 1 / 1 / 1 / 1 / 1 EN379  
4/ 5-13M OS / 1 / 1 / 1 / 1 / 1 EN379

Helmschale  
Dunkelstufen

Hersteller  
Optische Klasse  
Strahlklasse  
Homogenität  
Blickwinkelabhängigkeit  
Nummer der Norm

the marking on the welding filter indicates:

4/ 5-13 OS / 1 / 1 / 1 / 1 / 1 EN379  
4/ 5-13M OS / 1 / 1 / 1 / 1 / 1 EN379

Light shade  
Dark Shade range

Manufacturer  
Optical Class  
Diffusion of light class  
Homogeneity  
Angular dependence  
Norm

Le marquage apposé sur le filtre de protection pour soudeur signifie :

4/ 5-13 OS / 1 / 1 / 1 / 1 / 1 EN379  
4/ 5-13M OS / 1 / 1 / 1 / 1 / 1 EN379

Echelon de protection à l'état clair  
Échelon de protection à l'état foncé

Identification du fabricant  
Classe optique  
Classe de diffusion de la lumière  
Homogénéité  
Angulaire dépendance  
Marque de certification

Il kontrassegno riportato sul filtro di protezione per saldatore contiene i seguenti dati:

4/ 5-13 OS / 1 / 1 / 1 / 1 / 1 EN379  
4/ 5-13M OS / 1 / 1 / 1 / 1 / 1 EN379

Grado di protezione in stato chiaro  
Grado di protezione in stato scuro

Identificazione del fabbricante  
Classe ottica  
Classe della diffusione della luce  
Omogeneità  
Angolare dipendenza  
Numero della norma

Kennzeichnung Helmschale:

OS 175 B CE

Hersteller  
Nummer der Norm  
Mittlere Strahlenergie

Marking helmet shell:

OS 175 B CE

Manufacturer  
Number of the standard  
Medium energy impact

Marquages masque :

OS 175 B CE

Identification du fabricant  
Niveau de certification  
Impact moyenn énergie

Marcaggi maschera:

OS 175 B CE

Identificazione del fabbricante  
Numero della norma  
Impatto media energia

Kennzeichnung Vorsatzscheibe (EN166):

OS 1 B CE

Hersteller  
Optische Klasse  
Mittlere Strahlenergie

Marking safety cover plate (EN166):

OS 1 B CE

Manufacturer  
Optical class  
Medium energy impact

Marquages écran de protection extérieur (EN166):

OS 1 B CE

Identification du fabricant  
Classe optique  
Impact moyenn énergie

Marcaggi vetro di protezione esterno (EN166):

OS 1 B CE

Identificazione del fabbricante  
Classe ottica  
Impatto media energia

Kennzeichnung Innere Schutzscheibe (EN166):

OS F CE

Hersteller  
Niedrige Strahlenergie

Marking inside cover lens (EN166):

OS F CE

Manufacturer  
Low energy impact

Marquages écran de protection intérieur (EN166):

OS F CE

Identification du fabricant  
Impacte énergie basse

Marcaggi vetro di protezione interno (EN166):

OS F CE

Identificazione del fabbricante  
Impatto bassa energia

## Introduction

A welding helmet is a type of headgear used when performing certain types of welding to protect the eyes, face and neck from flash burn, ultraviolet light, sparks, infrared light, and heat. The helmet consists of several parts (see spare parts list). An automatic welding filter combines a passive UV and a passive IR filter with an active filter, the luminous transmittance of which varies in the visible region of the spectrum, depending on the irradiance from the welding arc. The luminous transmittance of the automatic welding filter has an initial high value (light state). After the welding arc strikes and within a defined switching time, the luminous transmittance of the filter changes to a low value (dark state).

Depending on the model, the helmet can be combined with a protective helmet and / or with a PAPR (Powered Air Purifying Respirator) system.

## Safety instructions

Please read the operating instructions before using the helmet. Check that the front cover lens is fitted correctly. If it is not possible to eliminate errors, you must stop using the cartridge.

## Precautions & protective restrictions / Risks

During the welding process, heat and radiation are released, which can cause damage to the eyes and skin. This product offers protection for the eyes and face. When wearing the helmet, your eyes are always protected against ultraviolet and infrared radiation, regardless of the shade level. To protect the rest of your body, appropriate protective clothing must also be worn. In some circumstances, particles and substances released by the welding process can trigger allergic skin reactions in correspondingly predisposed persons. Materials that come into contact with skin may cause allergic reactions to susceptible persons. The protective welding helmet must only be used for welding and grinding and not for other applications. The manufacturer assumes no liability when the welding helmet is used for purposes other than intended or with disregard for the operating instructions. The helmet is suitable for all established welding procedures, excluding gas and laser welding. Please note the recommended protection level in accordance with EN169 on the cover. Scratched or damaged lenses must be replaced. The helmet does not replace a safety helmet. Depending on the model, the helmet can be combined with a protective helmet.

The helmet can affect the field of view due to constructive specifications (no view on the side without turning the head) and may affect a color perception due to the light transmission of the auto darkening filter. As a result, signal lights or warning indicators may not be seen. Further there is an impact hazard due to a larger contour (head with helmet on). The helmet also reduces the audio and heat perception.

## Sleep mode

The cartridge has an automatic switch-off function, which increases the service life. If the light falls on the cartridge for a period of approx 10 minutes less than 1 Lux, it automatically switches off. To reactivate the cartridge, it must be briefly exposed to daylight. If the shade cartridge cannot be reactivated or does not darken when the welding arc is ignited, the batteries must be replaced.

## Warranty & liability

The warranty conditions can be found in the instructions of the manufacturer's national sales organisation. Contact your authorised specialist retailer for more details. A warranty is only given for material and manufacturing defects. In the event of damage due to improper use, unauthorised intervention or use not provided for by the manufacturer, the warranty and liability are void. Liability and warranty are also void if spare parts other than original spare parts are used.

## Expected Lifetime

The welding helmet has no expiration date. The product can be used as long as no visible or invisible damage or functional problems occur.

## How to use (Quick Start Guide)

- Head band. Adjust the upper adjusting band (p. 4) to the size of your head. Push in the ratchet knob (p. 4) and turn until the head band fits securely but without pressure.
- Distance from eyes and helmet angle. By releasing the locking knobs (p. 4-5), the distance between the cartridge and the eyes can be adjusted. Adjust both sides equally and do not tilt. Then tighten the locking knobs again. The helmet angle can be adjusted using the rotary knob (p. 5).
- Automatic/manual operating mode. The sliding switch (p. 6) is used to set the protection level setting mode. In automatic mode, the protection level is automatically adjusted to the intensity of the light arc via sensors (standard EN 379:2003). In manual mode, the protection level can be set by turning the knob (p. 6-7).
- Shade Level. In "manual" mode, the protection level can be set by the range slider between the range level SL5 to SL9 and SL9 to SL13. The fine adjustment can be set by turning the potentiometer knob (p. 6-7). In "automatic" mode, the protection level (SL5 – SL13) corresponds to standard EN 379, if the potentiometer knob (p. 6-7) is set to position "N". Turn the knob to extend the automatically set protection level by two protection levels up or down, depending on personal preference. (green inscription)
- Grinding mode. Press the Grind button (p. 6) to switch the cartridge to grinding mode. In this mode the cartridge is deactivated and remains in light mode. The activated grinding mode is indicated by the red flashing LED (p. 6) inside the helmet. To deactivate grinding mode, press the protection level knob again. After 10 minutes, the grinding mode is automatically reset.
- Sensitivity. With the sensitivity button the light sensitivity is adjusted according to the welding arc and the ambient light. The border of the "Super High" area is the standard sensitivity setting. By turning the knob, these can be customized. In the "Super High" area the maximum light sensitivity can be achieved.
- Sensor slider. The sensor slider can be set to two different positions. Depending on the position, the ambient light detection angle is reduced (p. 7) or increased (p. 7).
- Delay switch. The opening knob (Delay) (p. 7) allows to select an opening delay from dark to light. The knob allows infinite adjustment from dark to light between 0.1 to 2.0 s which protects the eyes.

## Cleaning and disinfection

The shade cartridge and the front cover lens must be cleaned with a soft cloth at regular intervals. No strong cleaning agents, solvents, alcohol or cleaning agents containing scouring agent must be used. Scratched or damaged lenses must be replaced.

## Storage

The welding helmet must be stored at room temperature and at low humidity. Storing the helmet in the original packaging will increase the service life of the batteries.

## Replacing the front cover lens (p. 8-9)

Push in one side clip to release the front cover lens and then remove it. Attach the new front cover lens to one side clip. Pull the front cover lens round to the second side clip and click in place. This action requires some pressure to ensure that the gasket on the front cover lens has the desired effect.

## Replacing the batteries (p. 9)

The cartridge has replaceable Lithium thin cell batteries, type CR2032. If you are using a welding helmet with a fresh air connection, you must remove the face seal before replacing the batteries. The batteries must be replaced when the LED on the cartridge flashes in green.

- Carefully remove the battery cover
- Remove the batteries and dispose of them in accordance with the national regulations for special waste
- Insert CR2032 type batteries, as shown
- Carefully replace the battery cover

If the shade cartridge does not darken when the welding arc is ignited, please check battery polarity. To check whether the batteries still have sufficient power, hold the shade cartridge against a bright lamp. If the green LED flashes, the batteries are empty and must be replaced immediately. If the shade cartridge does not operate correctly in spite of correct battery replacement, it must be declared unusable and must be replaced.

## Removing/installing the cartridge (p. 8)

- Pull out the protection level knob
- Carefully remove the battery cover
- Unlock the cartridge retention spring as shown
- Carefully tilt the cartridge out
- Unlock the satellite as shown
- Pull the satellite out through the gap in the helmet
- Rotate the satellite by 90° and push through the hole in the helmet
- Remove / replace the shade cartridge

The cartridge is installed in the reverse order.

## Troubleshooting

Cartridge does not darken

- Adjust sensitivity → Check the light flow to the sensor
- Change the sensor slider position → Select manual mode
- Clean sensors or front cover lens → Replace the batteries
- Deactivate grinding mode

Protection level too light

- Select manual mode → Replace front cover lens
- In automatic mode, adjust rotary knob by +1 or +2

Protection level too dark

- Select manual mode → In automatic mode, adjust rotary knob by -1 or -2

Cartridge flickers

- Adjust position of the delay knob on welding procedure
- Replace the batteries

Poor vision

- Clean the front cover lens or cartridge → Increase the ambient light
- Adjust the protection level to the welding procedure

Welding helmet slips

- Adjust/tighten the head band

## Specifications

(We reserve the right to make technical changes)

Shade Level	auto mode: SL4 (light mode) SL5 < SL13 (dark mode) manual mode: SL4 (light mode) SL5 < SL13 (dark mode)
UV/IR protection	Maximum protection in light and dark modes
Switching time from light to dark	170µs (23°C / 73°F) 110µs (55°C / 131°F)
Switching time from dark to light	0.1 - 2.0s with "Twilight Function"
Dimensions of cartridge	90 x 110 x 7mm / 3.55 x 4.33 x 0.28"
Dimensions of field of vision	50 x 100mm / 1.97 x 3.94"
Power supply	Solar cells, 2 pcs. LI batteries 3V (replaceable (CR2032))
Weight	Non PAPR: 500g / 17.637 oz PAPR: 700g / 24.6918oz
Operating temperature	-10°C - 70°C / 14°F - 157°F
Storage temperature	-20°C - 80°C / 4°F - 176°F
Classification as per EN379	Optical class = 1 Homogeneity = 1 Light scatter = 1 Angle of vision dependency = 1
Standards	CE, EAC, complies with ANSI Z87.1, ASNZS, CSA 294.3
Additional markings for PAPR version (notified body CE1024)	N12941 (TH3 in combination with e3000 or e3000X, TH2 for versions with hardhat and e3000 or e3000X) EN 14594 Class 3B

## Spare parts (p. 42)

- Helmet without cartridge (SP01) → Repair set 1 (Potentiometer knob, Sensitivity knob, Battery cover) (SP06)
- Cartridge incl. satellite (SP02) → Head band with fastener (SP07)
- Front cover lens (SP03) → Repair set 2 (SP04)
- Repair set 2 (SP04) → Sweat band (SP08 / SP09)
- Inner protection lens (SP05)

## Declaration of conformity

See internet link address at 2nd last page.

## Legal information

This document complies with the requirements of EU regulation 2016/425 point 1.4 of Annex II.

## Notified body

See 2nd last page for detailed information.